

STUDY OF THE EFFICIENCY OF REVERSE OSMOSIS SYSTEM FOR WATER DESALINATION

DOI:10.52113/3/eng/mjet/2013-02-02/17-29

Dr. Ra'id Tarik Hade

Anas B. Salman

dr.raidt@yahoo.com

anas1982_ewineew@yahoo.com

University of Al-Muthanna, College of Engineering

Department of Chemical Engineering

Abstract

This paper studied the effect of operating parameters on the efficiency of a small scale reverse osmosis with cellulose acetate (CA) membrane type has been studied. different samples were selected from several wells from different spots from Baghdad city. It was found that the highest system's efficiency can be attained at 36 °C temperature, 250 pressure, pH=3 and 2000 ppm salinity. Also it has been found that the reflux ratio is proportional to the pressure and temperature of feed water, and this ratio is inversely proportional with the pH and salinity of feed water. Four samples with different salinity values were selected from wells in south of Iraq.

Keywords: Reverse osmosis, Water desalination

دراسة كفاءة نظام تحليه المياه بالتناضح العكسي

د.م.انس بديوي سلمان

د.رائد طارق هادي

جامعة المثنى / كلية الهندسة

الخلاصة

في هذا البحث، تمت دراسة تأثير الظروف التشغيلية على كفاءة منظومة مصغرة لتحلية المياه بواسطة التناضح العكسي في الغشاء التناضحي من نوع (سيليلوز اسبيست). حيث تم استخدام عينات مختلفة من ابار موزعة على مناطق متفرقة من جنوب بغداد. تم التوصل الى انه اعلى كفاءة للمنظومة المستخدمة كانت تحت حرارة 36 م وضغط 250 بار وحامضية بمقدار $\text{pH} = 3$ وملوحة بمقدار 200 جزء بالمليون، كما تم التوصل الى انه نسبة الارجاع تتناسب تناسب طردي مع كل من الضغط والحرارة للماء الداخل الى المنظومة، كما تم التوصل الى انه نسبة الارجاع تتناسب تناسب عكسي مع حموضة وملوحة الماء الداخل الى المنظومة.

*Received at 30/9/2012

* Accepted at 31/1/2013

1- Introduction:

Water can be considered the most important element in our lives since the higher percent of our bodies consists of water. For this importance of water many of researches have been accomplished to improve and discover new methods for water purification and desalination. These methods were studied and improved depending on the conditions and mediums at which they were used. Also properties of feed and produced water were the main factors that affected the type of used desalination system. For example the water used for laboratories purposes will differ from the water used for drinking purposes and hence the type of treatment system will also differ from one use to another. Removing dissolved minerals including salts from brackish water, seawater and any water treatment process is called “Desalination Process”. Different operations have been developed for this purpose during last decades. Such as thermal distillation, reverse osmosis (RO), electro dialysis and vacuum freezing processes have been used for desalination purposes but the most two used processes are “Multi Stage Flash” and Reverse Osmosis (RO).(15). The most desired and proper process for seawater treatment is “Multi Stage Flash”,. High quality product water with salinity range between 1.0 and 50 ppm total dissolved solids (TDS) can be produced by thermal distillation processes, while water with salinity range between 10 and 500 ppm TDS can be produced by RO processes. (1) Generally Reverse Osmosis process consists mainly from four parts Pretreatment system, High-pressure pump, Membrane system, and Post-treatment system.[2]. Pre-treatment process is used to remove all suspended solids in order to minimize salt precipitation and microbial growth on the membrane. High pressure pump will supply the required pressure to force the water to diffuse through the membrane and the salts to be rejected. Membrane system consists of pressure vessel filled by semi-permeable membrane which will act as a diffusion medium. [3] Post-treatment system is the step at which the water prepared for distribution by adjusting its pH and other desired properties. Reverse osmosis systems can be mainly classified according to capacity and membrane type. Capacity refers to capacity of production rate, starting from small capacities such RO systems used for home uses to large capacity such RO systems used in hospitals and large projects. Classification according to membrane type depends on the type and size and material of construction of the membrane. Mainly two types of membrane exist; “Spiral wound” and “Hollow fiber”. The first type is mainly constructed from flat sheet membranes. In hollow fiber membrane the membrane will be consists of pressure vessel filled

with a large number of hollow fiber membranes. The type of used membrane depends mainly on the nature and pH of the feed water. For example hollow fiber membrane will accept solution which pH ranging from 4 to 9. a lower pH will result in corrosion of the metallic casing while higher pH would form encourage the formation of precipitate at the surface of the membrane. Each type of membrane has it's own optimum output in certain range of pH. In the acidic solution, it is assumed that the extra number of hydrogen ions must have an impact on the ions that exits in the solution.[4] Reverse Osmosis process affected mainly by a lot of factors such as

feed water composition, feed temperature, feed water pressure, permeate recovery and rate & degree of fouling and cleaning ability. [1] Helmy [1] found that the higher recovery ratio can be attained at higher operating pressure and higher feed temperature, while the increase in feed water pH and feed water salinity will lead to opposite effect. Wilf and Schierach [5] found that the operating parameters of seawater RO system are mainly function of feed water salinity and temperature. For example for seawater with 38,000 ppm TDS salinity and water temperature between 18-28 °C, the RO systems are designed to operate at a recovery ratio of 40 to 45% and with average permeate flux in the range of 11.9 to 13.5 L/m².hr. El-Saie et al [6] studied the effect of operating conditions such as feed water temperature, feed water pressure and recovery ratio on the permeate quality, production and system economy. Abou Rayan and Khaled [7] found that the reverse osmosis system is sensible to feed water temperature, and the quality of the product is highly affected by the working pressure by studying the operation of 2000 m³/day reverse osmosis desalination process for 6 years. Villafafila and Mujtabab [8] found that the higher pressure will lead to higher recovery ratio when they studied the effect of feed flow rate and feed pressure on the recovery ratio for reverse osmosis system. Abbas found that increasing the input pressure will increase the recovery ratio when he studied the effect of the operating conditions on reverse osmosis desalination system.

2- Experimental Work:

2-1- Raw materials:

Water used in this research was collected from four different wells taken from different spots in Baghdad. Properties of these samples of water illustrated in table below:

Table (I) Properties of feed water

Well number	Salinity ppm TDS
1	2000
2	2500
3	3000
4	4000

2-2- Apparatus

This work has been done by using system consist of a cellulose acetate (CA) membrane, water tank, water pump, electrical heater with voltage regulator, thermocouple with digital temperature reader, agitator with electrical motor, filters for pretreatment of feed water in order to remove any solid particles from the fed water, high pressure water pump, membrane element, piping and control valves. The water tank consist of stainless steel isolated tank (0.75 m³ capacity), and this tank is used as a reservoir for the feed water and at the same time to collect both permeate and brine streams output from the membrane. Electrical mixer was used in the tank to keep both the temperature and salinity and concentration homogeneous in the tank. Temperature was controlled by using electrical heater with voltage regulator to adjust temperature to desired values. Thermocouple with digital temperature reader was used to read the temperature inside the tank. A schematic diagram for apparatus is shown in fig. (1) below:

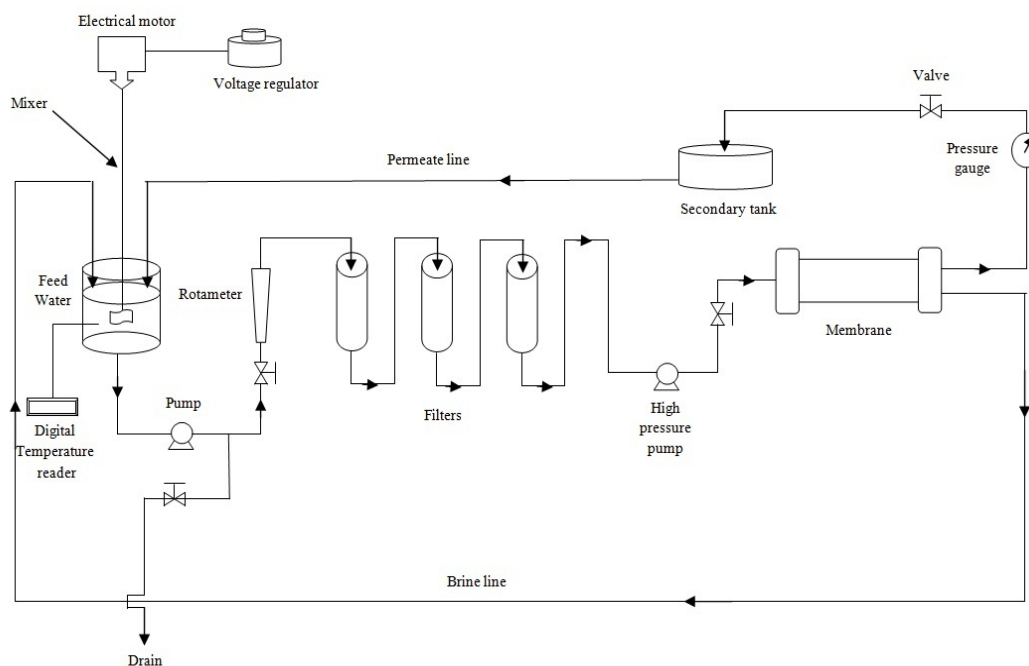

Fig.(1) Process flow diagram for the used reverse osmosis process

2-3- Procedure

In each set of runs some steps have been followed to obtain and control the desired conditions. Water was pumped from the tank by using water pump to pump the water through the filters in order to remove any odder and suspended solid particles. Then the outlet water from

these filters was pumped to the RO membrane by using a high pressure pump. Number of valves were used to control water flow rate into the RO membrane, flow meters were used to measure both permeate and brine flow rates. A secondary tank was used to take the samples for measurements. Acidity of samples was adjusted by addition of acid

2-3-1- Feed water temperature:

To study the effect of feed water temperature; the temperature of the feed water contained in the tank was adjusted to the desired values by using electrical heater with a voltage regulator then the electrical mixer has been turned on to make the temperature homogenous all over the tank. After the desired degree of temperature attained; the electrical pump has been started to pump the water through the filters. Then the high pressure pump will pump the water through the membrane. Valves were used to adjust input and output pressure at 200 & 185 bar respectively. After steady state attained; salinity and pH for permeate; feed water and brine have been recorded; flow rates for both brine and permeate have been recorded also. In this case; feed water temperature at each run will be kept at constant value.

2-3-2- Feed water pressure:

In this case our attention is to control input pressure. This will be done by using valve number A to adjust the input pressure to the desired value. In this set of runs at each run; input pressure will be kept at constant value. Other parameters will be recorded at each run.

2-3-3- Feed water salinity:

The feed water salinity will be kept constant. This will be done by mixing the water in the tank with salt solution. After that the pumps will be started and the water will be pumped through the system at constant input pressure. Temperature has been kept constant at the same value by using electrical heater with voltage regulator. Valves were used to keep input pressure at 250 bars. Other parameters at each run were recorded.

2-3-4- pH of feed water

pH for the feed water has been kept at constant value by mixing the feed water with salt solution. This salt solution will be added gradually to the tank until the desired pH value attained. After that the water will be pumped through the system and other parameters will be recorded at each run. Feed water pressure will be kept at constant value in all over the runs by using valves.

3- Results and Discussion:

In the present work, the main objective was to study the effect of feed water temperature, feed water pressure, feed water salinity and feed water pH on RO system. So in this work studying effect of each of the mentioned parameters will be done by varying one parameter and keeping the other three parameters constant. Changes happened in the other parameters as a result of changing varying this parameter have been recorded during each set of runs. The used water in these experiments has been brought from four wells in Baghdad, Iraq. Saline water was used to adjust the salinity and pH values into the desired value during the experiments.

3-1- Effect of feed water temperature

It can be seen from fig. (2), the increase in feed water temperature from 20 to 24 °C caused a decrease in permeate salinity, then from 22 to 36 °C that increase in temperature will cause an increase in permeate salinity. The overall range of variation in permeate salinity will be (89 - 184 ppm TDS) through (20 to 36 °C) temperature variation range. The reason for this behavior is believed that the increase in temperature will increase the solubility of salts in water, so it will be easier for the salt to pass through the membrane, and hence the salinity of permeate will increase. Negligible effect for temperature has been noticed above 36 °C since the permeate salinity will stay constant above this value of temperature. Helmy [1], used a Cross-linked Aromatic Polyamide membrane, and he reported an increase in salinity between 22 and 36 °C, and this behavior is nearly similar to present work. This behavior was expected since the type of the membrane will not change the temperature effect [9].

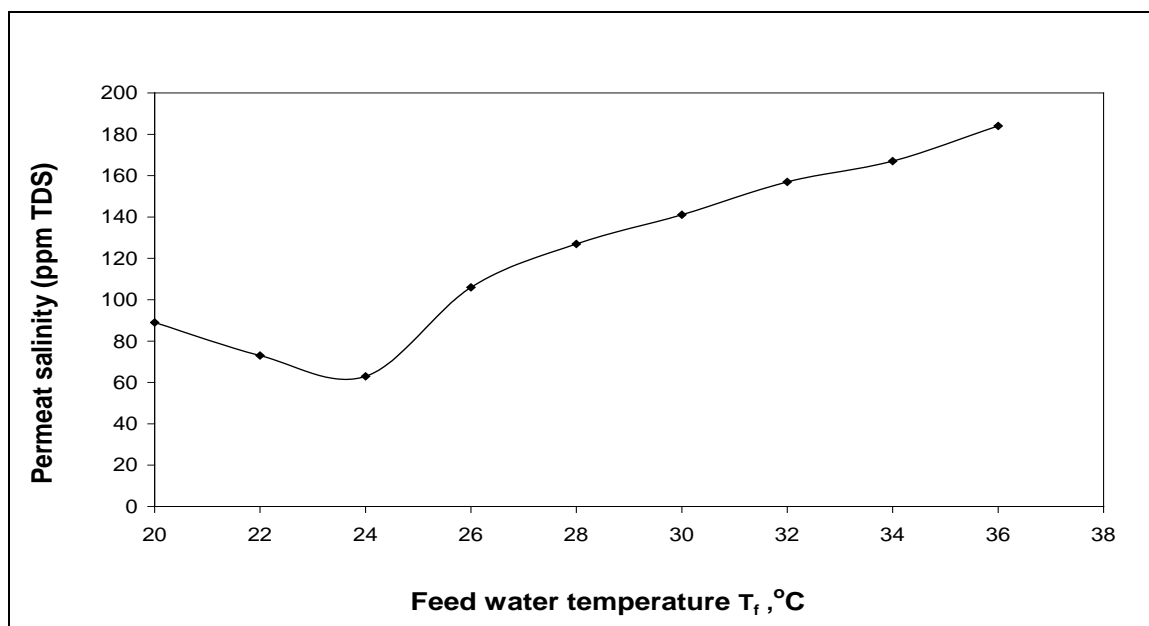

Fig. (2) Effect of feed water temperature on permeate salinity

When temperature is increased, the permeate pH varies as it can be seen in fig (3) that pH decreased with increasing the temperature. This is due to that the hydrogen ion (solubility increased with increasing the temperature then increasing the acidity of permeate solution.

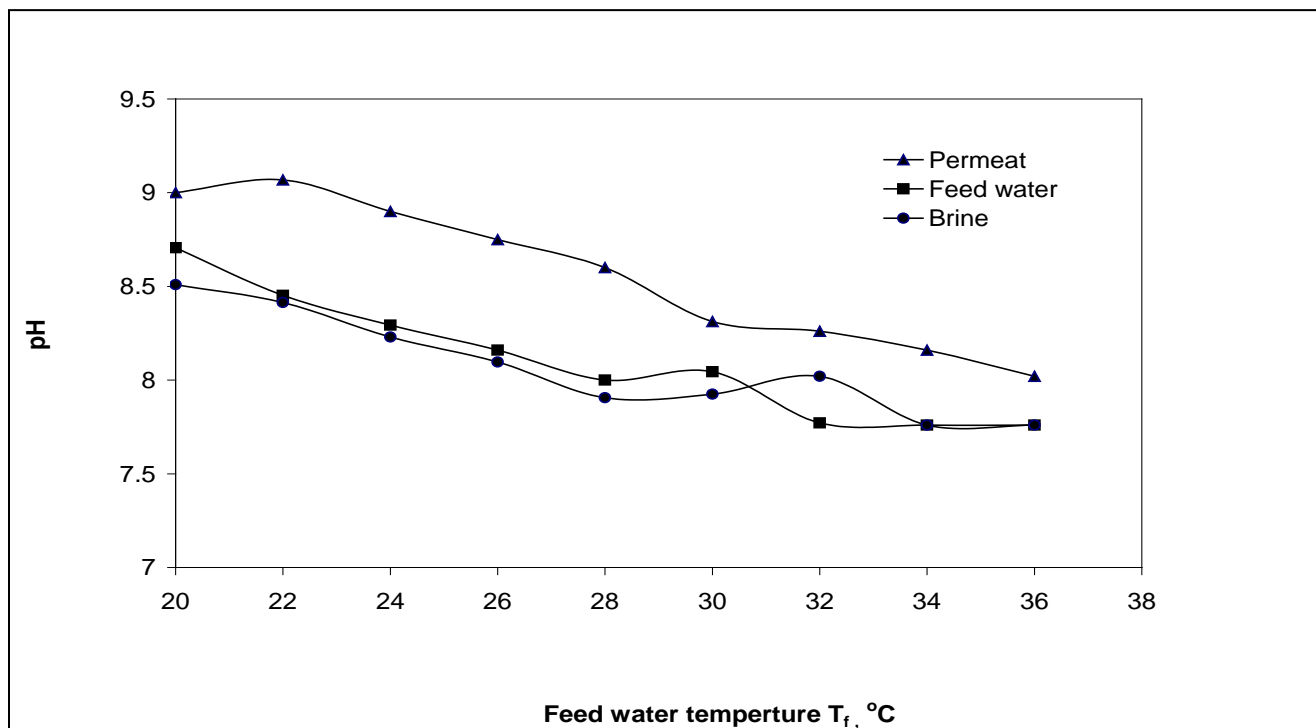

Fig. (3) Effect of feed water temperature on feed water, permeate and brine pH

3-2- Effect of feed water pressure

In this set of runs the feed water temperature and feed water salinity have been kept at 32 °C and 2700 ppm respectively. Permeate salinity decreased from 154 to 94 ppm TDS as the feed water pressure increase by the mentioned range, fig. (4) shows that effect. The increase in pressure led to increase in water flow rate through the membrane according to the following relation [9]:

$$Q_w = (\Delta p - \Delta \pi) K_w A / \tau \dots\dots (1)$$

Where:

Q_w = water flow rate through the membrane. (m^3 / hr)

Δp = Hydraulic pressure differential across the membrane. (kpa)

$\Delta \pi$ = Osmotic pressure differential across the membrane. (kpa)

K_w = membrane permeability coefficient for the water. ($m.kg / s^2.m^2$)

A = membrane area. (m²)

τ = membrane thickness. (m)

At the same time, increase in pressure did not affect the salt flux through the membrane, since the salt flow rate through the membrane is controlled by the relation [9]:

$$Q_s = \Delta C K_s A / \tau \dots\dots\dots (2)$$

Where:

Q_s = flow rate of salt through the membrane.

K_s = membrane permeability coefficient for salt.

ΔC = salt concentration differential through the membrane.

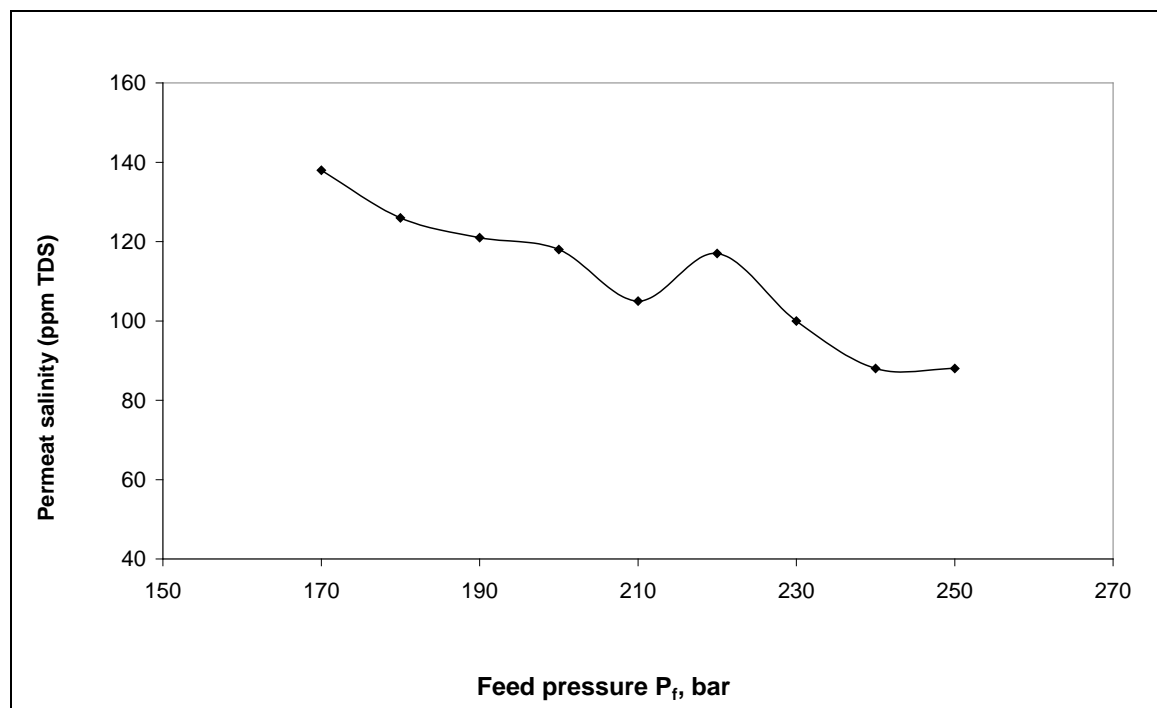

Fig(4) Effect of feed pressure on permeate salinity

Helmy [1] with Cross-linked Aromatic Polyamide membrane reported a salinity decrease from 140 to 83 where the pressure range was 130-210 bar, so lower pressure was required to obtain a wide range of decrease in permeate salinity, the reason for this is thought to be the membrane type, since the cross-linked aromatic polyamide membrane requires a pressure lower than that

required by the cellulose acetate (CA) membrane in order to get the same salinity from the same source [9].

3-3- Effect of feed water salinity

In this set of runs the temperature was kept constant (the variation in temperature value was negligible), and the pressure was kept at 250 bars. The increase in feed water salinity will cause an increase in permeate salinity as shown in fig. (5).

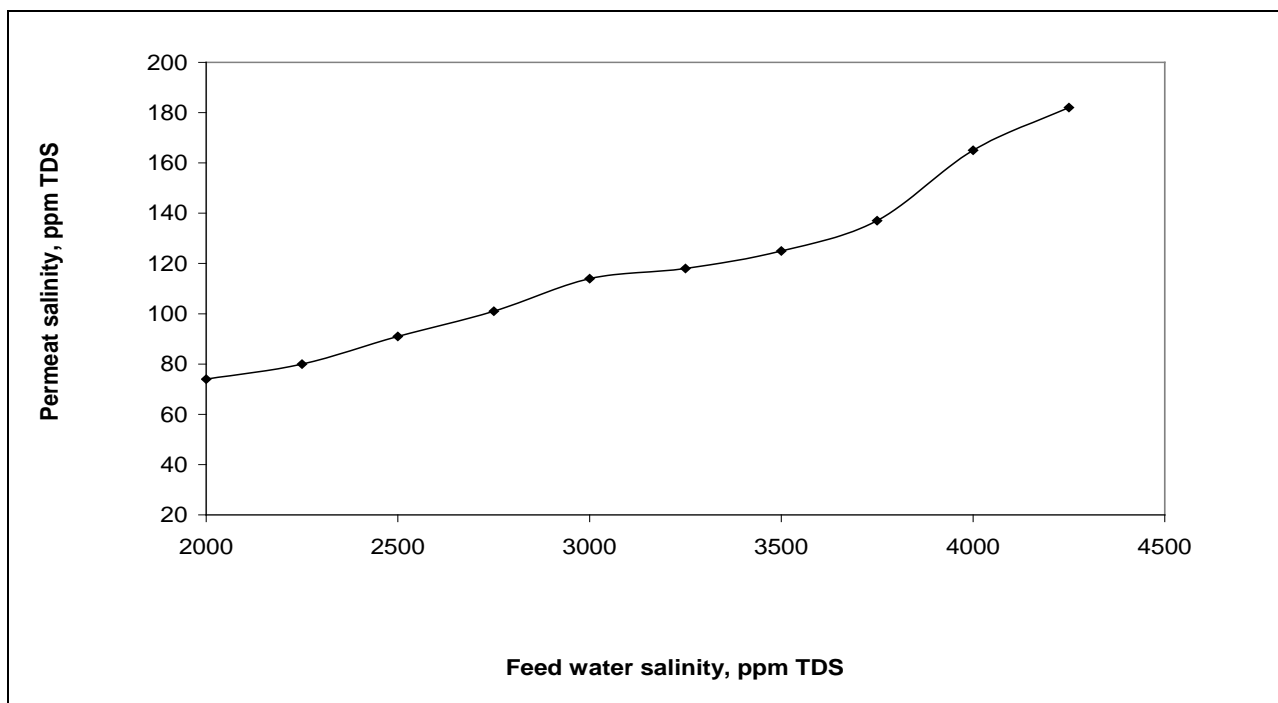

Fig.(5). Effect of feed water salinity on permeate salinity

Fig. (6). Showed the same effect with brine solution

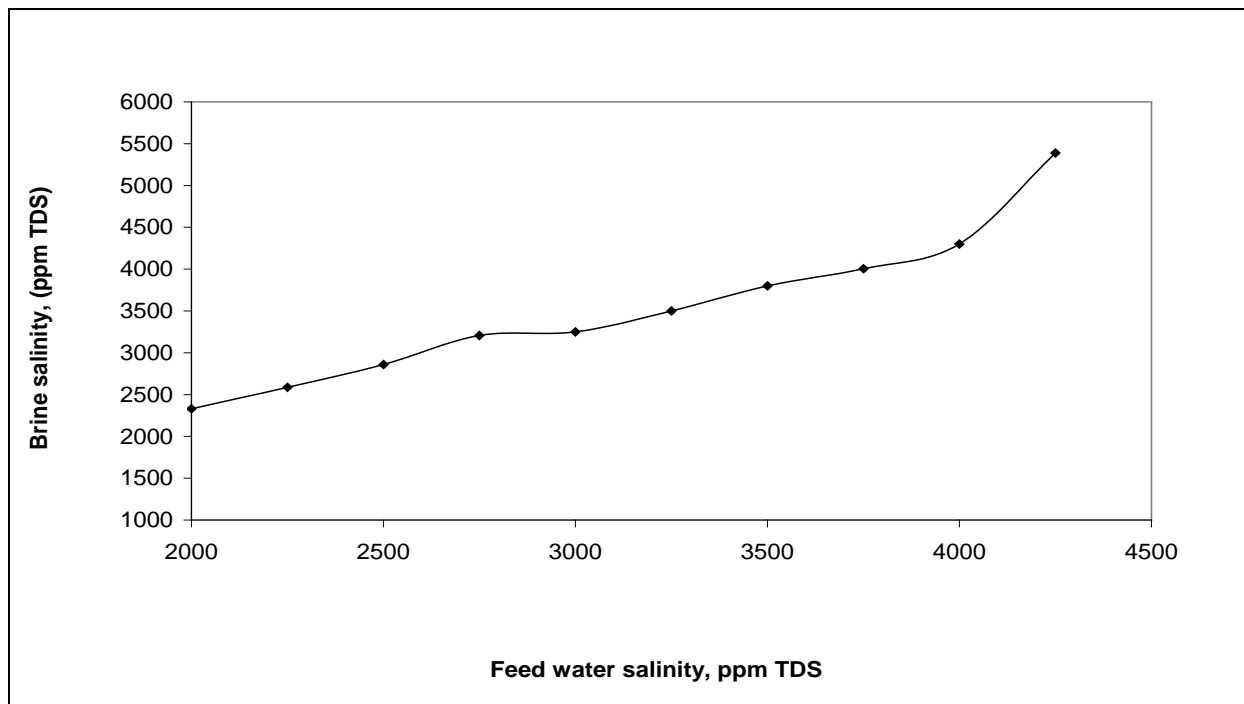

Fig .(6) Effect of feed water salinity on brine salinity

Equation 1 explained these behaviors. The increase in feed water salinity will increase the osmotic pressure differential across the membrane and hence decreasing the driving force for the water penetration, so smaller amount of water will pass and this will increase the salt concentration in the permeate stream. For a similar range of feed water salinity; Helmy [1] with cross-linked aromatic polyamide membrane reported a lower salinity, the reason for this is that the cross-linked aromatic polyamide membrane rejects a percent of salt higher than that rejected by the cellulose acetate (CA) membrane [9].

3-4- Effect of feed water pH

In this set of runs all the parameters except feed water's pH have been kept constant, where the temperature was kept at 32 °C, and pressure was kept at 250 bars. The pH value was adjusted to desired value by mixing the salt solution with the feed water tank. The increase of pH value from 3 to 9 caused an increase in permeate's pH value from 3.15 to 7.66, and by the same manner the brine pH increased from 3.37 to 7.78 as shown in fig. (7). permeate salinity increased from 349.7 to 538.1 ppm TDS while the brine salinity will decrease from 5544 to 5403 ppm TDS as shown in fig. (8) & fig. (9). The brine flow rate was very slightly affected by feed water pH

where it will be increased from 3.4 to 3.85 L/min in comparison with nearly equal decrease in permeate flow rate from 1.3 to 0.8 L/min as shown in fig. (10).

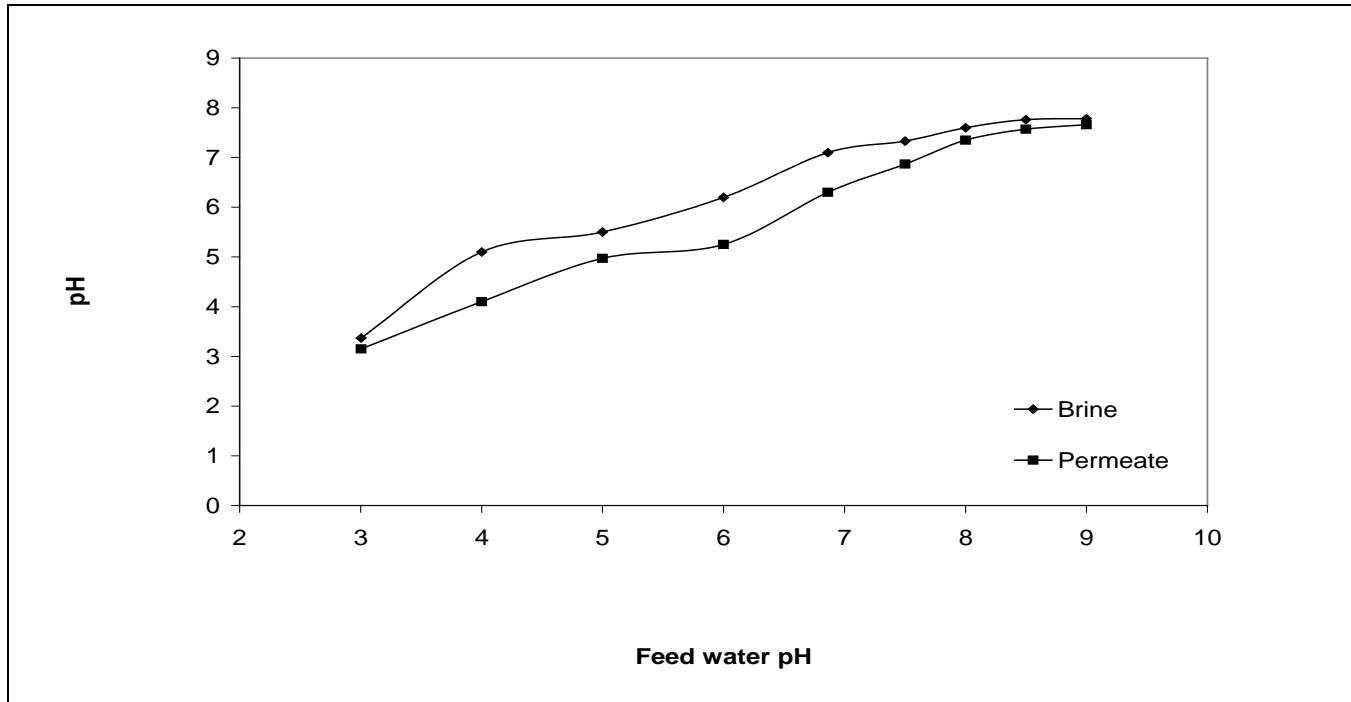

Fig. (7) Effect of feed water pH on brine and permeate pH

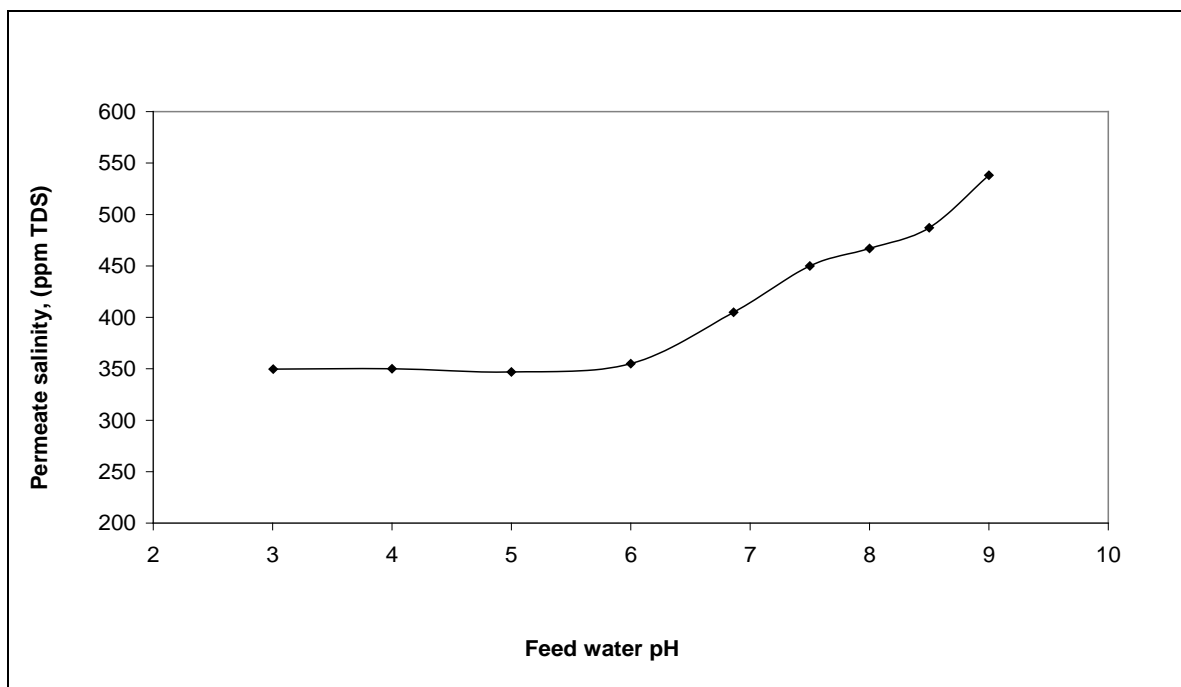

Fig.(8)Effect of feed water pH on permeate salinity

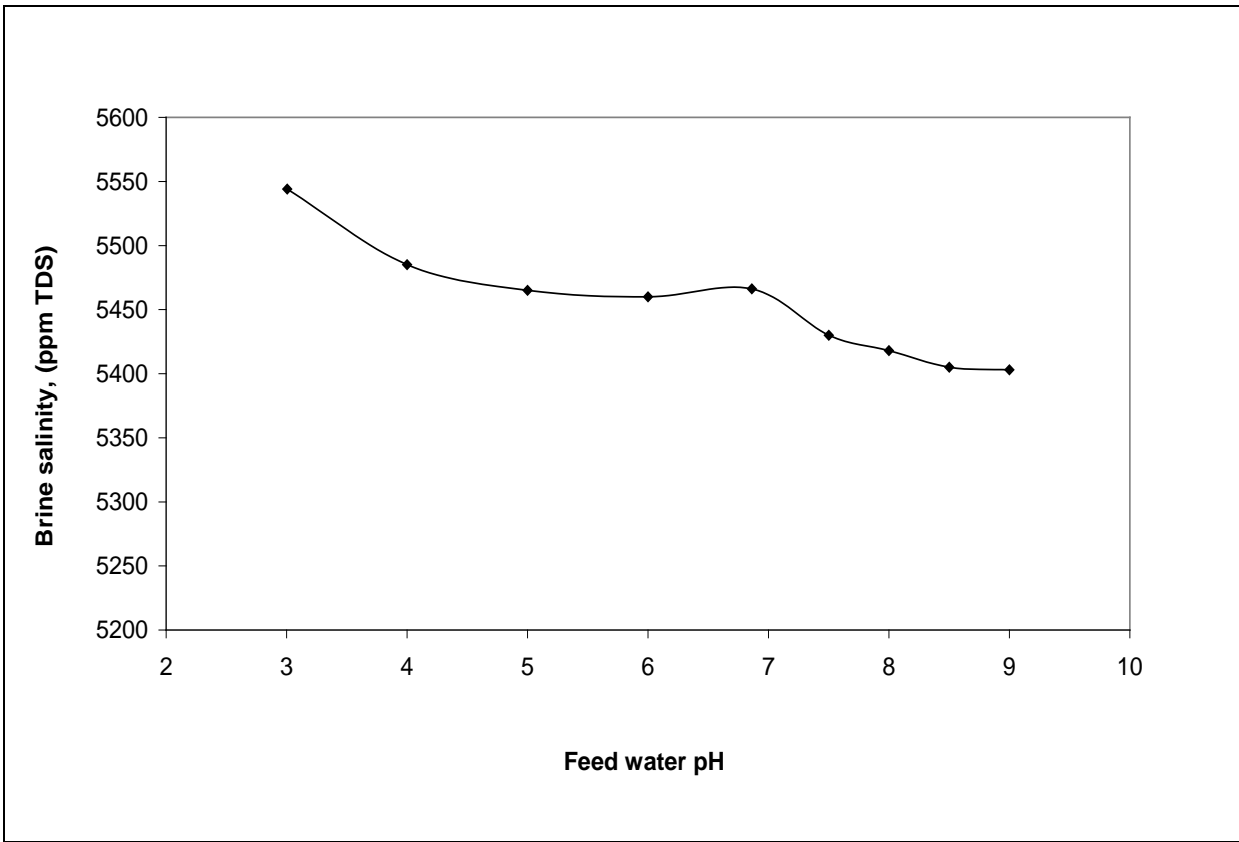

Fig.(9) Effect of feed water pH on brine salinity

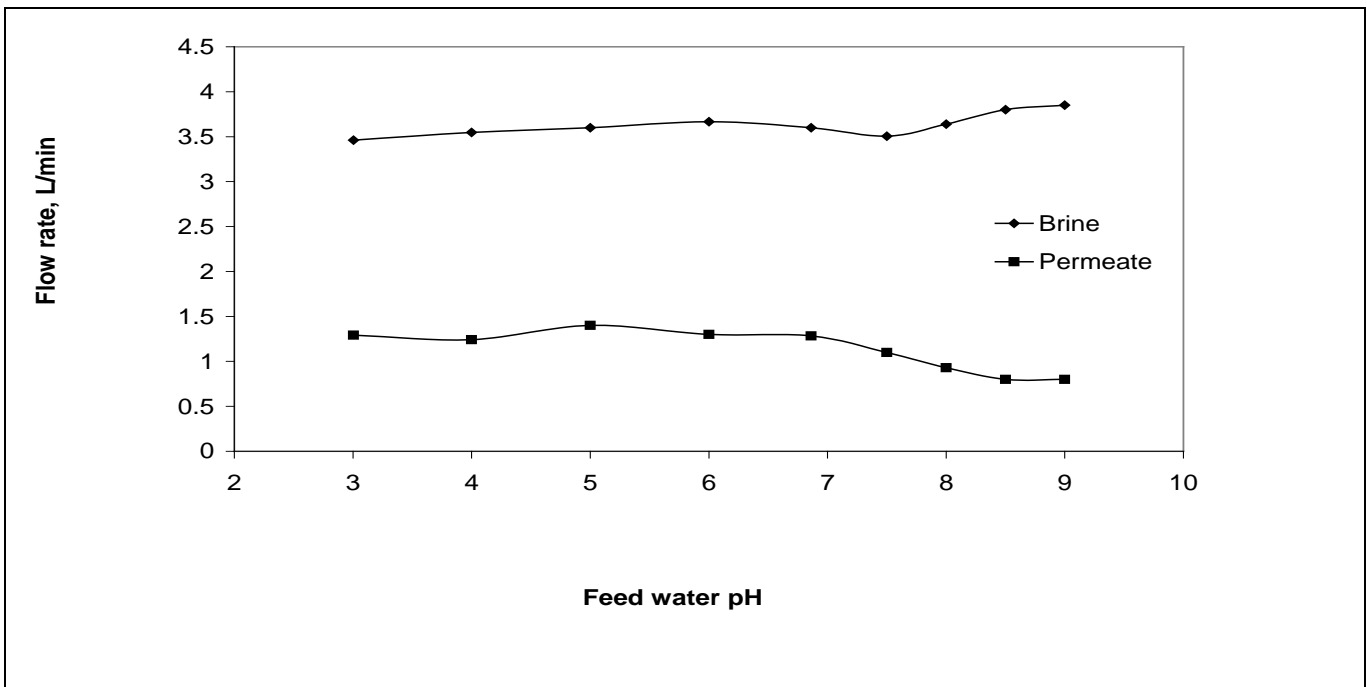

Fig.(10) Effect of feed water pH on brine and permeate flow rates

4- Conclusions

The efficiency of RO membrane affected by feed water temperature, feed water pressure, feed water salinity and feed water pH was studied. It was concluded that:

1. All of brine flow rate and feed water's pH and hence permeate and brine water pH is decreased by increasing temperature, while the permeate flow rate is increased by increasing temperature.
2. Higher permeate flow rate can be obtained by higher feed water pressure and lower brine flow rate can be obtained by higher pressure and the increase in pressure is decreased the permeate salinity.
3. Higher brine flow rate and lower permeate flow rate can be attained by higher feed water salinity. The increase in feed water.
4. increasing feed water pH caused a decrease in permeate flow rate and increase in brine flow rate. salinity will cause an increase in both permeate and brine salinity.

References

1. Berge D. and G.Helmy and K.Ibrahim, (2006), "An experimental investigation on the operating parameters affecting the performance of reverse osmosis desalination system", Tenth international water technology conference, IWTC 10, Alexandria, Egypt.
2. Arthur F. and Anderson R., (2003), "Reverse Osmosis". University of NEVADA.
3. Byrne, Wes.(1995), Reverse Osmosis, a Practical Guide for Industrial Users. Littleton, CO. Tall Oaks Publisher.
4. Sid O. and Peter R.,(2001)," Reverse Osmosis", Department of Engineering, National University of Singapore.
5. Wilf, M., and Schierach, M.K, (2001), "Improved Performance and Cost Reduction of RO Seawater System Using UF Pretreatment," Desalination, Vol.135, pp. 61-68.
6. El-Saie, M.H.A., El-Saie, Y.M.H.A., and Abd El Aziz, M., (2002), "Experimental RO Facility to Study the Heating Effect of Raw Water on the Varying Maine Parameters," Desalination Vol. 134, pp. 63-76.
7. Abou Rayan, M., and Khaled, I., (2002) ,"Seawater Desalination by Reverse Osmosis (Case Study)," Desalination, Vol. 153, pp. 245-251.
8. Abbas, A., (2004), "Simulation and Optimization of an Industrial Reverse Osmosis Water Desalination Plant," Proceeding of IMEC2004, International Mechanical Engineering Conference, December 5-8, Kuwait, IMEC04-2056.